

Encon[®]
SAFETY PRODUCTS

1-800-283-6266

Phone: (713) 466-1449 Fax: (713) 466-1703
E-Mail: customerservice@enconsafety.com



FREEZE RESISTANT SHOWER/ EYEWASH W/DRENCH HOSE

PART NUMBER: 01050314

SPECIFICATION:

Third party certified to ANSI Z358.1, the combination shower and eyewash with drench hose unit shall deliver 30 gpm (113.6 lpm) from the shower head, 3.2 gpm (12.1 lpm) from the eyewash and 3.0 gpm (11.4 lpm) from the drench hose attachment when supplied with 37 gpm (140.1 lpm) @ 30/70 psi (206.8/482.6 kPa). Unit shall provide a non-injurious stream of water for 15 minutes or longer. Shower, eyewash and drench hose shall be supplied with chrome plated (CP) bronze single motion activation stay open ball valves with CP balls. Unit shall include SS actuators with actuation graphics, schedule 80 hot dip galvanized steel piping and 1 1/4" supply/waste connection with flanged floor mounting plate for free-standing installation. A supplied automatic freeze protection valve shall open automatically when water temperatures are below 35°F (2°C) and closes at temperatures above 40°F (4.5°C). Unit must be supplied with self-adjusting 30 gpm (113.6 lpm) regulator on shower, 3.2 gpm (12.1 lpm) on eyewash and 3.0 gpm (11.4 lpm) on drench hose to assure constant flow and pattern under 30/70 psi (206.8/482.6 kPa) hydraulic conditions. Shower head to be manufactured of UV resistant high visibility yellow ABS plastic to deliver a minimum of 20" (50.8cm) diameter pattern to the target area 60" (152.4cm) above standing level. Eyewash to be mounted in a high visibility ABS Yello-Bowl[®]. Eyewash and drench hose heads with float off covers to be manufactured of UV resistant ABS plastic. Float off covers are secured with stainless steel bead chains and provided to inhibit dust and/or contamination when not in use. Combination units that provide improper flow pattern or contain deteriorating screens/filters are not acceptable. Combination unit shall be Encon Safety Products Model 01050314.

MATERIALS OF CONSTRUCTION:

- PIPING:** Schedule 80 hot dip galvanized steel.
- VALVE:** Chrome plated bronze stay open ball valves with chrome plated balls, stainless steel (S/S) valve stems, S/S push plate with actuation graphic (eye/facewash and drench hose) and S/S pull rod assembly with actuation graphic (shower). Valve sizes: shower 1", eye/facewash and drench hose 1/2".
- SHOWER HEAD:** Yellow ABS plastic shower head.
- EYEWASH HEAD:** ABS plastic dual stream heads with ABS plastic float off covers secured with stainless steel bead chains.
- BOWL:** High visibility ABS plastic Yello-Bowl[®].
- DRENCH HOSE:** 6' (182.9cm) rubber hose assembly with ABS plastic single stream head with ABS plastic float off cover secured with stainless steel bead chains. Mounting bracket included.
- REGULATOR:** Self-adjusting 30 gpm (113.6 lpm) shower, 3.2 gpm (12.1 lpm) eyewash and 3.0 gpm (11.4 lpm) drench hose regulators.
- FREEZE VALVE:** Automatically opens when internal water temperature reaches 35°F (2°C) and closes at temperatures above 40°F (4.5°C).
- SUPPLY:** 1 1/4" NPT
- WASTE:** 1 1/4" NPT
- WEIGHT:** 62 lbs

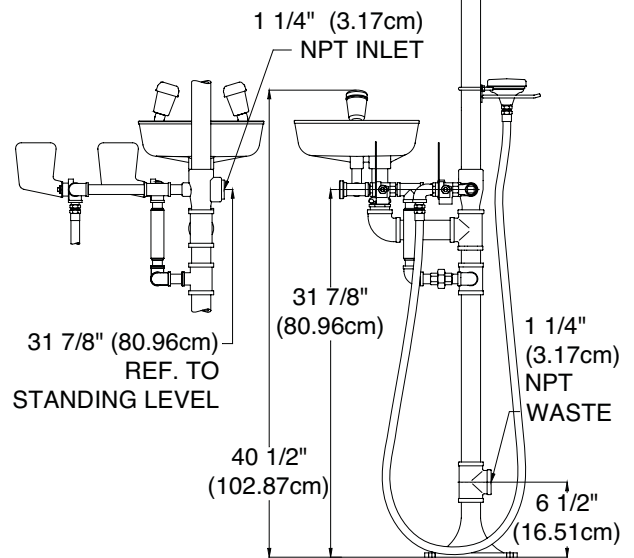
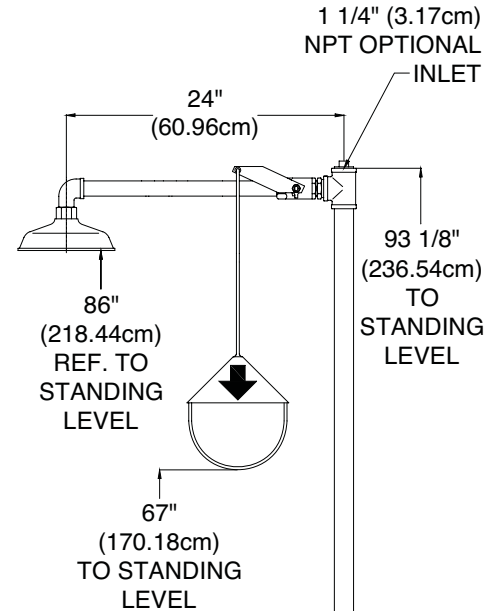

MODEL #	DESCRIPTION
01050314	Unit as Specified