



1-800-283-6266

Phone: (713) 466-1449 Fax: (713) 466-1703

E-Mail: customerservice@enconsafety.com

THROUGH WALL FREEZE RESISTANT EYE/FACEWASH PART NUMBER: 01035606

SPECIFICATION:

Third party certified to ANSI Z358.1, the eye/facewash unit shall deliver 8.0 gpm (30.3 lpm) @ 30/70 psi (206.8/482.6 kPa) of flowing pressure. Eye/Facewash shall provide a non-injurious stream of water for 15 minutes or longer. Unit shall be supplied with 1/2" chrome plated (CP) single motion activation stay open ball valve with CP ball. Valve and supply line mounted inside building through wall to resist freezing. Eye/Facewash shall include SS actuator with actuation graphic and 7" X 11" (17.8cm X 27.9cm) sign. An automatic drain shall be provided to evacuate water from exposed piping after use to prevent freezing. Unit must be supplied with self-adjusting 8.0 gpm (30.3 lpm) regulator to assure a constant and even dual stream flow pattern under 30/70 psi (206.8/482.6 kPa) hydraulic conditions. Eye/Facewash heads with float off covers to be manufactured of UV resistant ABS plastic shall be mounted on outside wall. Float off covers are secured with stainless steel bead chains and provided to inhibit dust and/or contamination when not in use. Eye/Facewash units that provide improper flow pattern or contain deteriorating screens/filters are not acceptable. Eye/Facewash shall be Encon Safety Products Model 01035606.

***Note:** Allow minimum 16" (40.64cm) lateral clearance between shower and eyewash target areas for actuator arm movement.

MATERIALS OF CONSTRUCTION:

- PIPING:** Schedule 80 hot dip galvanized steel piping.
- VALVES:** 1/2" chrome plated bronze stay open ball valve with chrome plated ball, stainless steel valve stem and stainless steel push plate with actuation graphic.
- HEAD:** ABS plastic dual stream head and ABS plastic float off covers secured with stainless steel bead chains.
- REGULATOR:** Self-adjusting 8.0 gpm (30.3 lpm) regulator assures a constant and even dual stream flow pattern under varying hydraulic conditions.
- AUTOMATIC DRAIN:** Water drains from exposed piping after use to resist freezing.
- SUPPLY:** 1/2" NPT
- WEIGHT:** 9 lbs (4.08 kgs)

MODEL #	DESCRIPTION
01035606	Unit as Specified

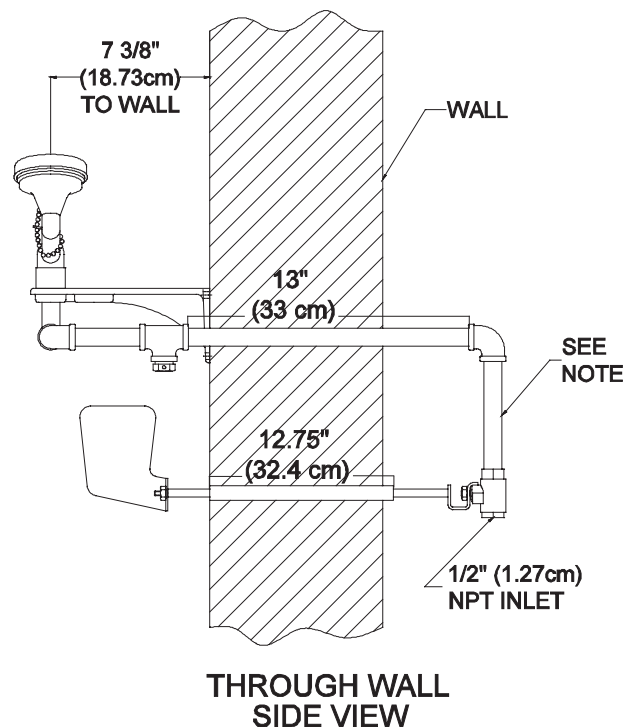
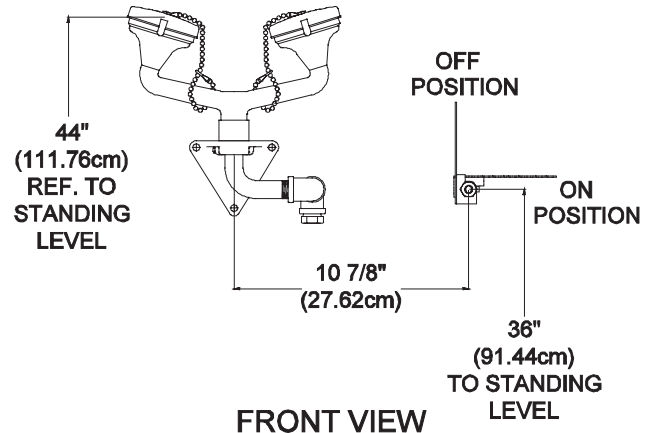

NOTE:
COMPONENTS ARE SHOWN IN VERTICAL ORIENTATION FOR CLARITY. ACTUAL ASSEMBLY/INSTALLATION TO BE HORIZONTAL AS SHOWN IN FRONT VIEW.