

**PRESSURIZED PORTABLE  
EYEWASH/DRENCH HOSE STATIONS****PRODUCT DESCRIPTION**

Pressurized, portable self-contained eyewash/drench hose stations designed for use in areas where plumbed potable water is not available. The heated pressurized portable stations (120 VAC or 12 VDC models) are designed to maintain water temperature in the vessel between 60° and 90°F (15° and 32°C),  $\pm 5^\circ\text{F}$  (2.8°C) to help prevent cold water shock to the user. All pressurized portable stations are air tested at factory.

**GENERAL INFORMATION**

Pressurized portable eyewash/drench hose stations do not require hydrostatic testing of the vessel unless otherwise specified by an authority having jurisdiction. The maximum working pressure of the vessel is 130 psi (896.3 kPa). The relief valve on the 5 gallon (18.9 liter) and 13 gallon (49.2 liter) stations is designed to open at 125 psi (861.8 kPa). The relief valve on the 37 gallon (140 liter) is designed to open at 110 psi (758.4 kPa).

Following are requirements of ANSI Z358.1 for Self-Contained Emergency Eyewash Equipment. A complete copy of this standard may be obtained from International Safety Equipment Association.

1. Eyewash stations shall be in accessible locations that require no more than 10 seconds travel time from the farthest hazard.
2. Eyewash stations shall be assembled and installed in accordance with the manufacturer's instructions.
3. Prior to putting Eyewash Station into service, performance test of the equipment shall be performed in accordance with the following procedures:
  - a. Fill the vessel with flushing fluid. Open valve to full open position. Valve should open in one second and remain open without requiring further use of the operator's hands.
  - b. With valve in the "full on" position, measure the flushing fluid flow pattern with the use of a test gauge to determine a suitable eye-wash pattern as required by ANSI standards.
  - c. A performance test on the 13 (49.2 liter) and 37 gallon (140 liter) eyewash stations should include ensuring the station is capable of delivering a minimum of 0.4 gpm (1.5 lpm) of flushing fluid for 15 minutes.
4. Visually check the self-contained eyewash station to determine if flushing fluid requires change of fluid or supplemented and air replaced.
5. Eyewash stations shall be inspected annually for proper operation to ensure compliance to ANSI Z358.1 standard.
6. Each station location shall be identified with a highly visible sign or integral decal. The area around the unit should be well lit.

**TRAINING**

All employees who might be exposed to hazardous material shall be instructed in the location and proper use of emergency eyewash/drench hose units. Experiences have shown that initial first-aid treatment for irritants should be to irrigate the eyes and face for 15 minutes prior to medical treatment. It is important to hold the eyelids open and roll the eyes so water will flow on all surfaces and in the folds surrounding the eyes.

**CAUTION:**

- 1) Tank is designed as a limited pressure vessel.
- 2) Do not drop or impact the eyewash vessel or external components.
- 3) Use the installed carry handles or an adequate cart to transport the eyewash station. Damage to vessel or bodily injury may occur if improperly handled.
- 4) Avoid prolong exposure to sunlight and ambient heat sources above 95°F (35°C).

# ASSEMBLY AND INSTALLATION INSTRUCTIONS

## NOTES:

- 1) Pressurized portable eyewash stations are shipped empty. Air and flushing fluid to be supplied by others.
- 2) Some portable drench hose models are fully assembled and some models require partial assembly. Follow the instructions below applicable to your model.

## NON-HEATED PRESSURIZED PORTABLE EYEWASH / DRENCH HOSE STATIONS

1. Remove plastic cap from the fitting located on top of vessel, and connect eyewash/drench hose piping assembly to the fitting.
2. Tighten piping assembly using pipe wrench and appropriate pipe sealant. **Do not over tighten.** Piping assembly should thread easily and should be tightened to ensure that leaking will not take place.
3. Attach plush plate over stem of ball valve and secure tightly with lock nut provided.
4. Thread eyewash head assembly onto end of piping assembly using appropriate pipe sealant. **Do not use sealant tape.** Hand tighten until snug. Once snug, rotate back until eyewash heads are aligned with push plate (when in off position). **Do not over tighten.**
5. Release lid lock to remove lid from vessel.
6. Fill vessel with clean potable water to the appropriate fill-line. Do not add Hydrosep® water preservative for testing purposes.
7. Replace lid and secure with lid lock. Ensure lid is sealed.
8. Pressurize vessel to the green bar area on pressure gauge (see chart below) with clean dry air source by way of the air valve stem. Air valve stem and pressure gauge are located on top of vessel. Pressure will drop slightly after initial filling due to cooling of compressed air. Allow approximately 20 minutes for this pressure to drop. Add additional air to restore pressure to the green bar area as required.

AIR LEVEL CHART	
5 Gallon (18.9 liter) Vessel	100 psig (689.5 kPag)
13 Gallon (49.2 liter) Vessel	100 psig (689.5 kPag)
37 Gallon (140 liter) Vessel	110 psig (861.8 kPag)

9. Visually inspect eyewash unit for several minutes to ensure no leaks are present. If leaks are present, check to verify that ball valve is properly closed, vessel lid is sealed, and all fittings are secure (water and air).
10. Test eyewash assembly for proper fluid flow pattern by activating eyewash valve to open position for a few seconds.
11. Records should be maintained verifying compliance with testing procedures.
12. When testing is completed and satisfactory, fill eyewash station using the following instructions:

**CAUTION: Portable unit must be de-pressurized prior to removing lid.**

- a) **PRIOR TO OPENING VESSEL DEPRESSURIZE UNIT** by pulling the pressure relief valve ring to open valve. Hold open until pressure gauge indicator falls to "0" mark.
  - b) When de-pressurization of the vessel is complete, release lid lock to remove lid.
  - c) Refill vessel with flushing fluid to appropriate fill-line. It is recommended Hydrosep® water preservative (included) be added to the vessel fluid supply when using potable water. Follow directions on Hydrosep® container.
  - d) Pressurize vessel as instructed in Step 8 above.
13. Place pressurized portable eyewash/drench hose station at desired location.

## HEATED PRESSURIZED PORTABLE EYEWASH / DRENCH HOSE STATIONS

1. Complete Steps 1 through 7 in the Assembly and Installation Instructions above.
2. Connect power to unit using the power cord (included). Insert the 3-prong male plug into a suitable functional 120-volt electrical outlet or connect power cord to a suitable 12 VDC battery, which ever is applicable.
3. After two hours (120 VAC), check fluid temperature in the vessel to verify heater is activated. (Heat time for 12 VDC is approx. 12 hours.) NOTE: Approximate heat times are based on water temperature of 45° F (7.2°C).
4. Continue the installation process by following Steps 8 through 13 in the Assembly and Installation Instructions section above.

**NOTE:** Fluid temperature is controlled by two self-regulating thermostats.

## OPERATION AND MAINTENANCE

**CAUTION: Disconnect power source from unit prior to attempting maintenance.  
Portable unit must be de-pressurized prior to opening vessel.**

**NOTE:** Should internal vessel components in the heated models require replacement or repair, contact Encon Customer Service at 800-283-6266 for discussion and/or instructions on returning portable unit for evaluation.

1. Care must be taking when handling eyewash/drench hose station to avoid damage.
2. Ensure eyewash/drench hose heads are covered when not in use.

## OPERATION AND MAINTENANCE – continued

3. A regularly scheduled maintenance program should include visual inspection, testing, and cleaning. A weekly visual inspection on filled units should include:
- Check pressure gauge for proper pressure. Pressure gauge indicator should be within the green bar area.
  - Check for any damage to the vessel, fittings, piping and nozzles. Replace external components as necessary.
  - Check weight of unit to determine fluid level. Refer to chart. If vessel requires flushing fluid, remove lid to add fluid to appropriate fill-line. **CAUTION: Portable unit must be de-pressurized prior to removing lid.**

MODEL	WEIGHT EMPTY	WEIGHT FULL
5-Gallon Unit	12 lbs. (5.4 kg)	42 lbs. (19 kg)
13-Gallon Unit	33 lbs. (14.9 kg)	108 lbs. (49 kg)
13-Gallon Heated	36 lbs. (16.3 kg)	111 lbs. (50.3 kg)
37-Gallon Unit	89 lbs. (40.3 kg)	295 lbs. (133.8 kg)

- d) On heated models, confirm heater is working by placing hand on top of vessel to verify vessel external temperature is at approximate 80° - 90°F (26.7° - 32.2°C). If deemed necessary, fluid temperature may be verified using a thermometer. Remove vessel lid and insert thermometer. **CAUTION: Portable unit must be de-pressurized prior to removing lid.** If fluid temperature does not reach 85°F (29°C) or exceeds 95°F (35°C), contact Encon Customer Service at 800-283-6266 for discussion and/or instructions on returning portable unit for evaluation.
- NOTE:** Should internal vessel components on heated pressurized models require replacement or repair, contact Encon Customer Service at 800-283-6266 for discussion and instructions on returning portable unit for evaluation.
4. With the pressure relief valve subjected to a pressure of at least 75% of the set pressure, before each refill (Step 5 below) lift the pull ring to verify free action and discharge of the valve. Inspect and remove any foreign material and mineral build-up around the seat of the valve, as necessary.
5. Vessel should be drained of fluid, flushed, and refilled with flushing fluid every 30 days. More often if condition warrants. If Hydrosep® water preservative additive is used, vessel should be drained of fluid, flushed, and refilled with potable water and Hydrosep® every 120 days (not to exceed 180 days). Follow directions on Hydrosep® container.
- PRIOR TO OPENING VESSEL DEPRESSURIZE UNIT** by pulling the pressure relief valve ring to open valve. Hold open until pressure gauge indicator falls to "0" mark.
  - When de-pressurization of the vessel is complete, release lid lock to remove lid.
  - Remove eyewash head assembly from eyewash piping assembly and set on a clean surface.
  - Empty remaining water from vessel.
  - Rinse the vessel internally and externally to remove any foreign material. Care should be taken when handling vessel to prevent damage.
  - Inspect eyewash/drench hose head assembly for any dirt or foreign material in heads. Rinse as necessary.
  - Replace eyewash/drench hose head assembly to piping assembly. For instructions, refer to Assembly and Installation section, Step 4 on page 3.
  - After inspection and tests are completed, refill vessel to appropriate fill-line and restore pressure to the green bar area as necessary.
  - Replace eyewash/drench hose station back in service.
6. Records should be maintained verifying compliance with inspection procedures.

## WARRANTY STATEMENT

ENCON HEREBY DISCLAIMS ALL WARRANTIES EXPRESSED OR IMPLIED INCLUDING BUT NOT LIMITED TO WARRANTIES OF MERCHANTABILITY, FITNESS FOR A PARTICULAR PURPOSE, AND NON-INFRINGEMENT OF THIRD-PARTY RIGHTS, EXCEPT AS HEREINAFTER PROVIDED.

Encon Safety Products warrants that for one year from the date of purchase of any Encon products, the product will be free of defects in materials and workmanship if properly used and cared for or cleaned under normal conditions in accordance with Encon's use and care instructions and properly installed, if applicable, in accordance with Encon's installation instructions. With respect to the product, Encon's only obligation and purchaser's exclusive remedy under this warranty is to repair or replace such product; provided that:

- Encon is notified of the defect within one year of shipment, and
- the product is determined by Encon to be defective.

Encon requires proof of original ownership as proof of warranty coverage, and Encon must receive any claim under this Limited Warranty within one year of purchase of the product.

NOTWITHSTANDING ANYTHING TO THE CONTRARY CONTAINED HEREIN, ENCON SHALL NOT BE LIABLE FOR LOSS, DAMAGE, OR EXPENSE ARISING DIRECTLY OR INDIRECTLY AS A CONSEQUENCE OF USE OF THE EQUIPMENT WITH OTHER PRODUCTS OR FROM ANY OTHER CAUSE, INCLUDING ANY CONSEQUENTIAL, INCIDENTAL, SPECIAL OR EXEMPLARY DAMAGES, EXCEPT FOR ENCON'S OBLIGATION TO REPAIR OR REPLACE DEFECTIVE PRODUCTS AS EXPRESSLY PROVIDED IN THIS STATEMENT.

Replacement parts purchased from Encon are warranted for one year following the shipment of such replacement part, or until the expiration of the warranty period for the product, whichever is less. No warranty is given in connection with products that are altered without Encon's expressed written consent. The same warranty limitations and the obligations of Encon as set out herein above shall apply to replacement parts.

Encon's total liability arising out of this warranty (including, but not limited to, warranty claims) regardless of forum and regardless of whether such action or claim is based on tort, contract or otherwise will not exceed the total purchase price of the product.

## REPLACEMENT PARTS LIST

ITEM #	P/N	DESCRIPTION	ITEM #	P/N	DESCRIPTION
1	01052111A	Eyewash Dual Stream Head Assembly, 0.4 gpm	8	00014314	Air Pressure Gauge
2	01052131	Float Off Cover w/ 8 inch Chain	9	00013038	Tank Lid, SOLID (5 & 13 gal. models)
3	01052017	Push Plate (5 gal. models)	10	01105005	Hand-held Drench Hose Subassembly includes chrome plated brass self-closing squeeze valve w/ spray nozzle, recoil hose, & brass fittings. (5 & 13 gal. models)
	01052018	Push Plate (13 & 37 gal. models)			
4	00011038	Pressure Relief Valve, 125 psi (5 & 13 gal. models) (Models with solid tank lids)	11	01052124	Spray Nozzle Assembly w/ 0.4 gpm Regulator
	00011075	Pressure Relief Valve, 110 psi (37 gal. models) (Models with solid tank lids)	12	00011046	Hand-held Squeeze Valve (aerator not included)
5	01052041	ABS Drench Hose Head (37 gal. models)	13	00014337	Recoil Hose Replacement Kit, red w/ Brass Fittings, 1/4 inch x 8 ft.
6	01052020	Drench Hose Float Off Cover w/ 10 inch Chain (37 gal. models)	14	50005000	Hose Replacement, black w/ Brass Fittings, 3/8 inch x 8 ft.
7	00011003	1/2" Chrome Plated Bronze Ball Valve			

## OPTIONAL ACCESSORIES AVAILABLE

- 01105003 Dolly Cart, Tubular Steel Frame, for 10 & 13 gal. models
- 01103008 Dolly Cart, Yellow ABS, for 10 & 13 gal. models
- 01110300 Dolly Cart, Tubular Steel Frame, for 37 gal. models
- 01112894 Inspection Tag
- 01110764 Hydrosep® Water Preservative (4 – 8 oz. bottles/case)

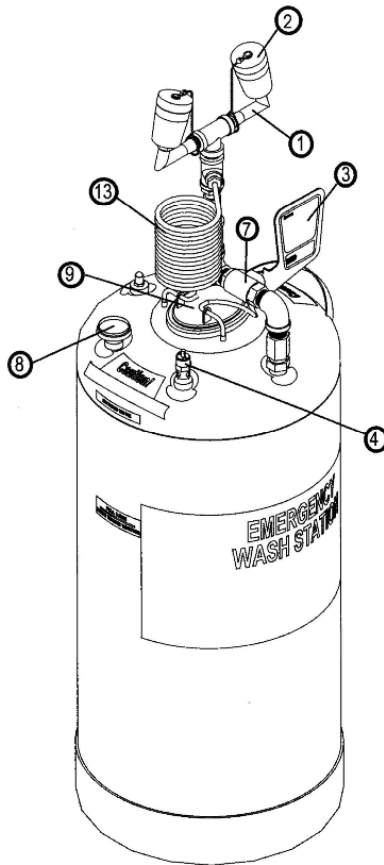
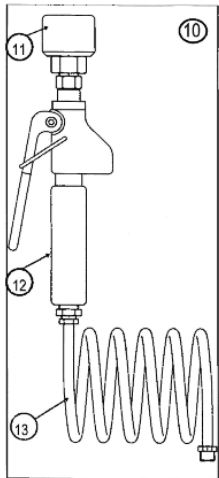

13-Gallon Portable Eyewash Station  
shown as reference

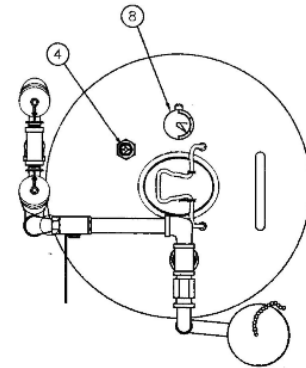

TOP VIEW

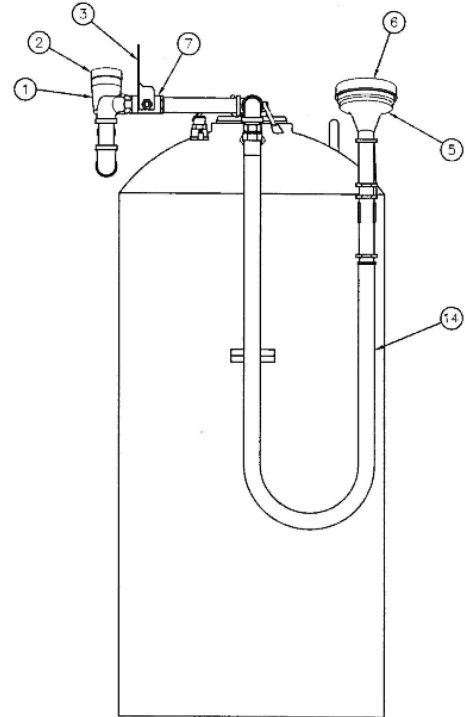

SIDE VIEW

37-Gallon Portable Eyewash Station  
shown as reference



6825 W. Sam Houston Pkwy. N (77041)  
P.O. Box 3826 • Houston, Texas (77253)  
(713) 466-1449 • Fax (713) 466-1819  
1-800-AT-ENCON / 1-800-283-6266  
E-Mail: [customerservice@enconsafety.com](mailto:customerservice@enconsafety.com)  
Website: [www.enconsafety.com](http://www.enconsafety.com)