

PRODUCT DESCRIPTION

The Emergency Eye/Facewash Mixing Valve shall control and maintain the temperature of the water to the station. Unit shall be self contained and include a thermostatic water mixing valve, a dial thermometer on the outlet, union angle checkstops, wall mounting bracket, piping and fittings factory assembled and tested, top or bottom inlets and top outlet, unit set for 85°F (29°C) and a maximum temperature of 90°F (32°C). Unit must be able to be set to the correct temperature for the industry recommendations but must be locked in place to prevent changing of the temperature by accident. Unit must be checked weekly for performance in conjunction with the requirements of ANSI Z358.1. Unit shall be able to flow a minimum flow of 20 GPM (76 l/min) at 30 PSI (2.1 Bar).

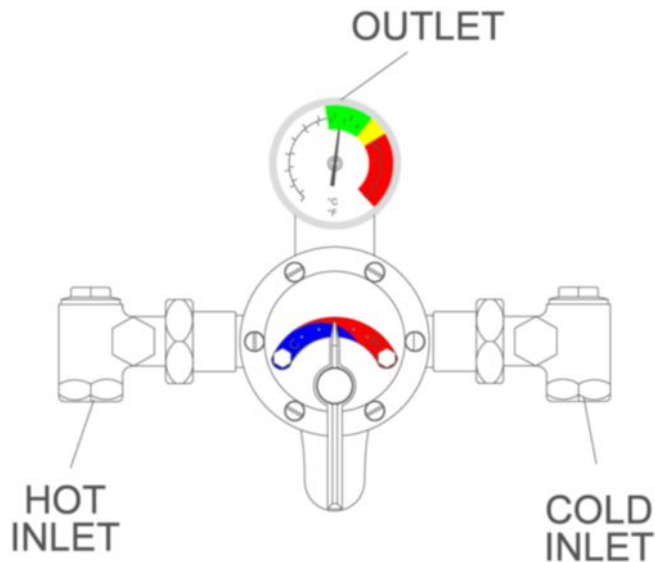

INSTALLATION

Valve should be installed at a location where it can easily be cleaned, adjusted or repaired.

The inlets are clearly marked on the valve body casting. Connect the hot water into the inlet marked "HOT" and cold water into the inlet marked "COLD." These are NOT to be confused with the "C-H" markings on the front cover. Union angle strainer checkstops furnished must be installed on both supply lines as shown above.

Use solder or pipe cement sparingly. Supply pipes should be flushed before the valve is connected. Flush outlet pipe and valve as soon as it is connected.

Maximum Operating Pressure 125PSI (860 KPA) for Hot and Cold Water.

NOTE: It may be necessary to recirculate the tempered water to the face/eyewash should the piping be exposed to excessive hot or cold conditions. Consult factory for proper piping.

CAUTION

IMPORTANT! These systems are designed to provide mixed water from 60 to 90°F (15 to 32°C) for emergency shower applications only. Contact Encon for systems designed to operate at temperatures outside of this range.

REMEMBER! THIS IS A CONTROL DEVICE WHICH MUST BE CLEANED AND MAINTAINED ON A REGULAR BASIS. (SEE MAINTENANCE GUIDE AND RECORD, MGR-1001).

ADJUSTMENT AND SERVICE

Encon Thermostatic Water Mixing Valves are simple in design and may be easily cleaned, adjusted and repaired. If the installation is accessible, servicing may be completed without disconnecting the valve.

NOTE: Thermostatic Water Mixing Valves are REGULATING mechanisms, which must be regularly maintained to provide best performance. Frequency of cleaning depends on quality of local water conditions and usage. (See Maintenance Guide and Record MGR-1000 and ANSI 358.1).

TO RESET ADJUSTABLE HIGH TEMPERATURE LIMIT STOP:

1. Loosen LTR set screw.
2. Remove SNAP CAP, SCREW & WASHER.
Remove POINTER.
3. Temporarily place POINTER on the spline rod, turn HANDLE to the left, allow cold water to flow. Slowly adjust handle to the right to required maximum temperature. (Temperatures above 90°F are not recommended on Emergency equipment, consult medical advisor for correct temperature settings).
4. Replace POINTER on the spline rod so that its RIGHT edge is resting against the STOP SCREW located on the RIGHT SIDE OF THE COVER.
5. The new maximum temperature has now been set. Test this temperature by holding a thermometer under the flow of water to be certain it is as desired.

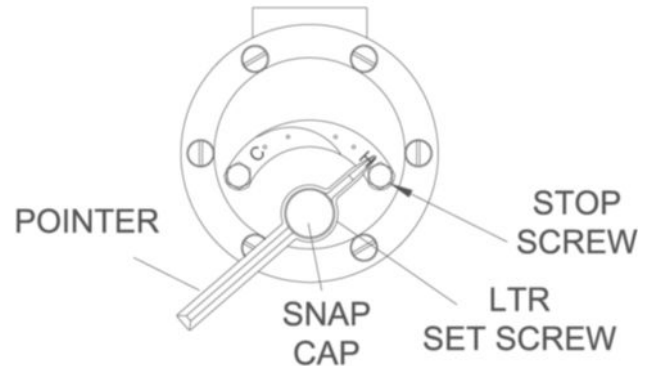

WARNING

WARNING! This Thermostatic Mixing Valve has an adjustable high temperature limit stop which must be checked. If temperature is too high, the installer **MUST RESET** stop immediately. Always check the temperature of the mixed water when the lever handle is turned to full **HOT**. If the Emergency Drench equipment is a combination type, the water temperature must be checked at each outlet (FACE/EYEWASH /SHOWER) location independently, Excessively hot water is **DANGEROUS AND MAY CAUSE SCALDING!**

Consult medical advisor for correct temperature setting.

The high temperature limit stop is factory set at approximately 90°F (32.2°C) with an incoming hot water supply temperature of 135°F (57°C). If the incoming hot water on the job is higher than 135°F, the valve when turned to full hot will deliver water in excess of 90°F and the high temperature limit stop **MUST BE RESET BY THE INSTALLER.**

TROUBLESHOOTING INSTRUCTIONS

PACKINGS & GASKETS	Leak at pointer rod. Leak between valve cover and base.	REPAIR KIT 1/50M
PORT SLEEVE ASSEMBLY	Valve delivers either all hot or all cold water, or will not mix consistently.	REPAIR KIT TGM-1/50M or REPAIR KIT R/50M
THERMOSTAT GROUP	After cleaning or replacing port sleeve assembly, valve will not hold temperature.	REPAIR KIT TGM-2/50 or REPAIR KIT R/50M
CHECKSTOPS	Hot water bypass in cold line. Supplies cannot be shut off completely. Leak at checkstop bonnet.	REPAIR KIT 2/50M

SEE PAGE 5 FOR COMPLETE PARTS BREAKDOWN AND PARTS KITS

If installed on a circulated hot water system, make certain the valve is piped according to Encon Required Methods of Piping (see page 3).

REMEMBER! THIS IS A CONTROL DEVICE WHICH MUST BE CLEANED AND MAINTAINED ON A REGULAR BASIS. (SEE MAINTENANCE GUIDE AND RECORD, MGR-1000).

REQUIRED METHOD OF PIPING ECC-STV-800-LF VALVES

Required when hot water is to be circulated to a thermostatic mixing valve, which is a substantial distance from the hot water source. Recommended Hot Water Inlet Temperature 140°F (60°C).

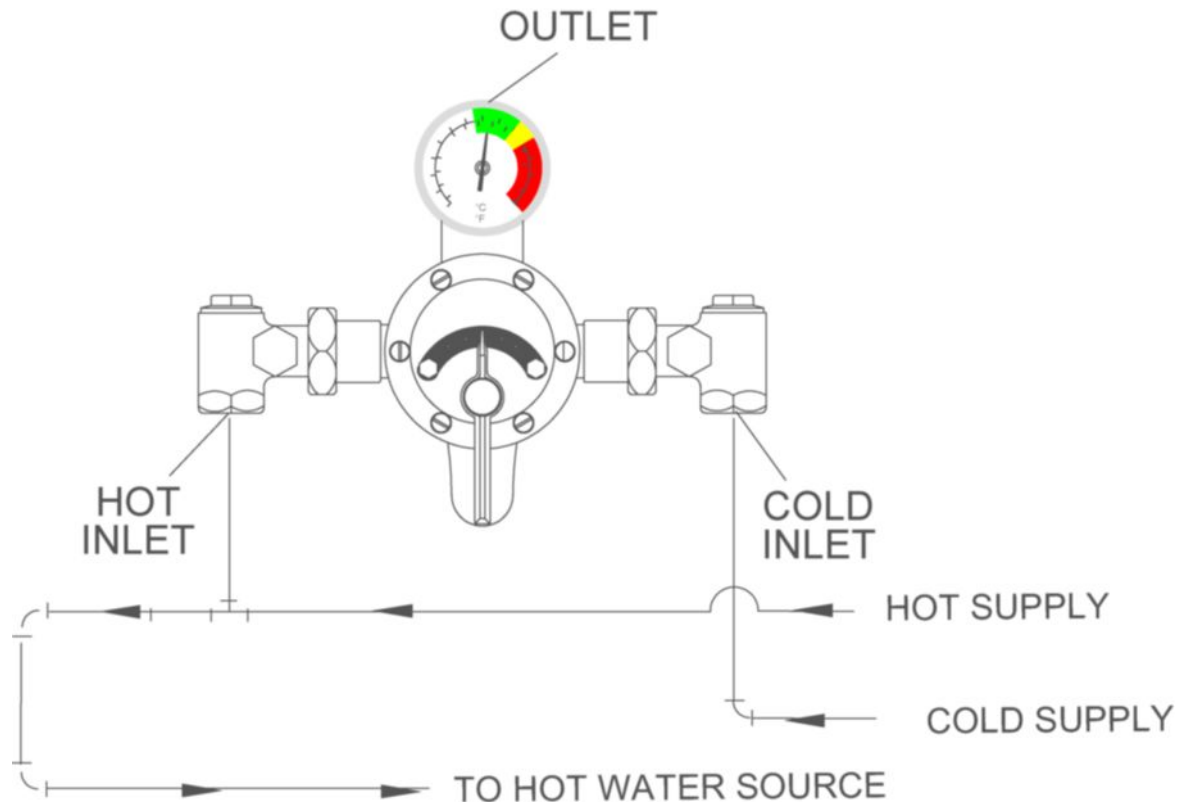

This unit must be cycled each time the emergency equipment is checked. See ANSI Z358.1, Maintenance and Training section.

Open drench or combination emergency shower and allow temperature to reach the set point. Temperature will drop when secondary valve opens to cool output.

Turn primary thermostatic valve to full cold and wait ten seconds, this will close secondary valve.
Turn primary thermostatic valve to full hot and wait for ten seconds.

Check to be sure outlet temperature does not climb above 90°F (32°C) or above recommended maximum temperature set by medical advisor.

Turn primary thermostatic mixing valve to full cold and wait ten seconds.

Set primary thermostatic mixing valve to the desired temperature and close drench or combination emergency shower.

INSTRUCTIONS FOR DISMANTLING VALVE

Shut off hot and cold supplies to valve.

Loosen POINTER SET SCREW, Remove SNAP CAP, SCREW and WASHER, POINTER and FRICTION SPRING. (FIGURE #1).

Remove the 6 COVER SCREWS, then take off cover to which the Thermostat and Gears are attached.

WHEN RE-ASSEMBLING VALVE, insert new Flange Packing in base; replace COVER, tightening COVER SCREWS in rotation; put FRICTION SPRING in place; then replace POINTER and POINTER ROD SCREW, WASHER and CAP.

After installing new parts, it will probably be necessary to reset Pointer to obtain correct temperature range from Cold to Hot. See page 2 instructions "TO RESET ADJUSTABLE HIGH TEMPERATURE LIMIT STOP."

TO CLEAN PORT SLEEVE ASSEMBLY

Failure to properly blend the water may be caused by a sticking condition in the PORT SLEEVE ASSEMBLY. The THIMBLE should slide freely on the PORT SLEEVE.

If a deposit of lime or sediment prevents free movement, use a nail set or other tapered tool to unscrew the CHECK NUT as far as it will go, then screw the PORT SLEEVE NUT into the base. This will release the PORT SLEEVE and THIMBLE so they can be lifted out, (Figure #2).

Clean with a NON-CORROSIVE CLEANING AGENT AND SOFT CLOTH - DO NOT USE ABRASIVES - then wash parts thoroughly, wipe with a dry cloth and re-assemble. The PORT SLEEVE should be assembled with the elongated holes to the right (COLD SIDE). Tighten PORT SLEEVE NUT against end of PORT SLEEVE but be careful not to over tighten, this may deform port sleeve. Tighten CHECK NUT.

When replacing front be sure DRIVING BALL is inserted in Ball Socket as shown in Figure #1.

TO REPLACE POINTER ROD WITH GEAR

Loosen POINTER SET SCREW, remove POINTER ROD SNAP CAP, SCREW, WASHER, POINTER, and FRICTION SPRING. (FIGURE #1)

Remove COVER with parts attached, from the front of valve.

Remove COIL SLEEVE STUD and take off THERMOSTAT GROUP.

Replace POINTER ROD with GEAR and re-assemble.

TO REPLACE (OR CLEAN) THERMOSTAT GROUP

Follow instruction for replacing POINTER ROD with GEAR above. If a deposit has collected on the Thermostatic Coil, clean it off with a brush in a non-corrosive grit-free cleaning solution.

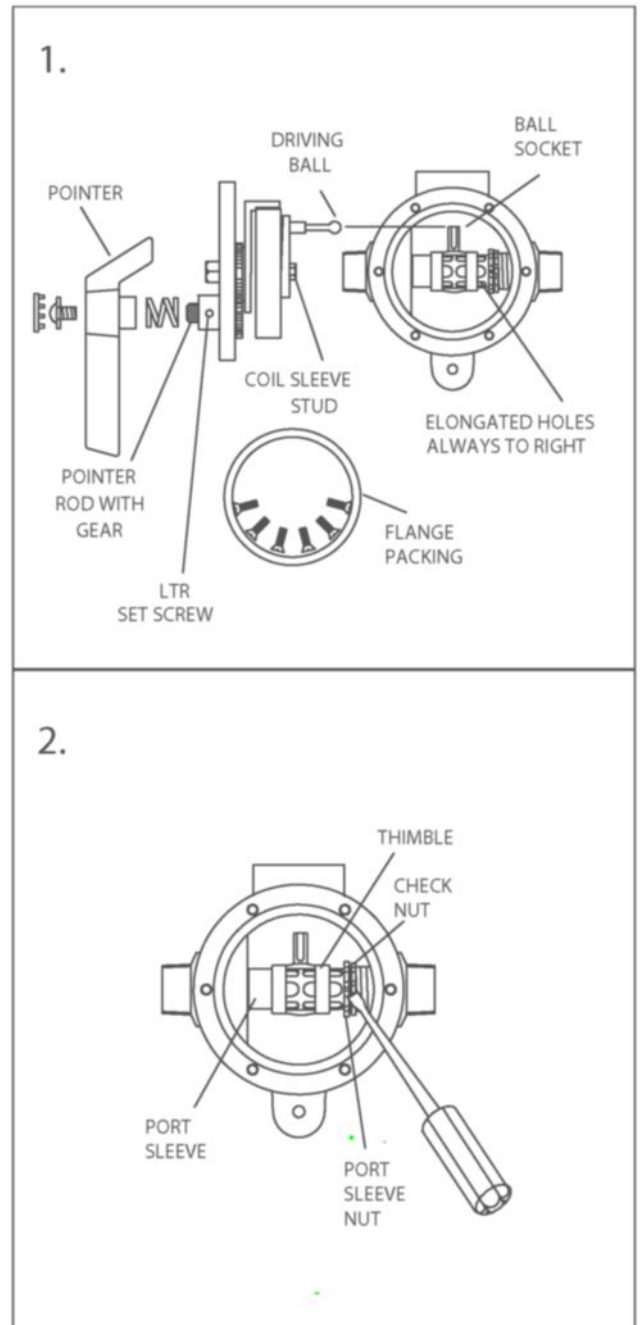

REMEMBER! THIS IS A CONTROL DEVICE WHICH MUST BE CLEANED AND MAINTAINED ON A REGULAR BASIS. (SEE MAINTENANCE GUIDE AND RECORD, MGR-1000)

ECC-STV-800-LF VALVE PARTS

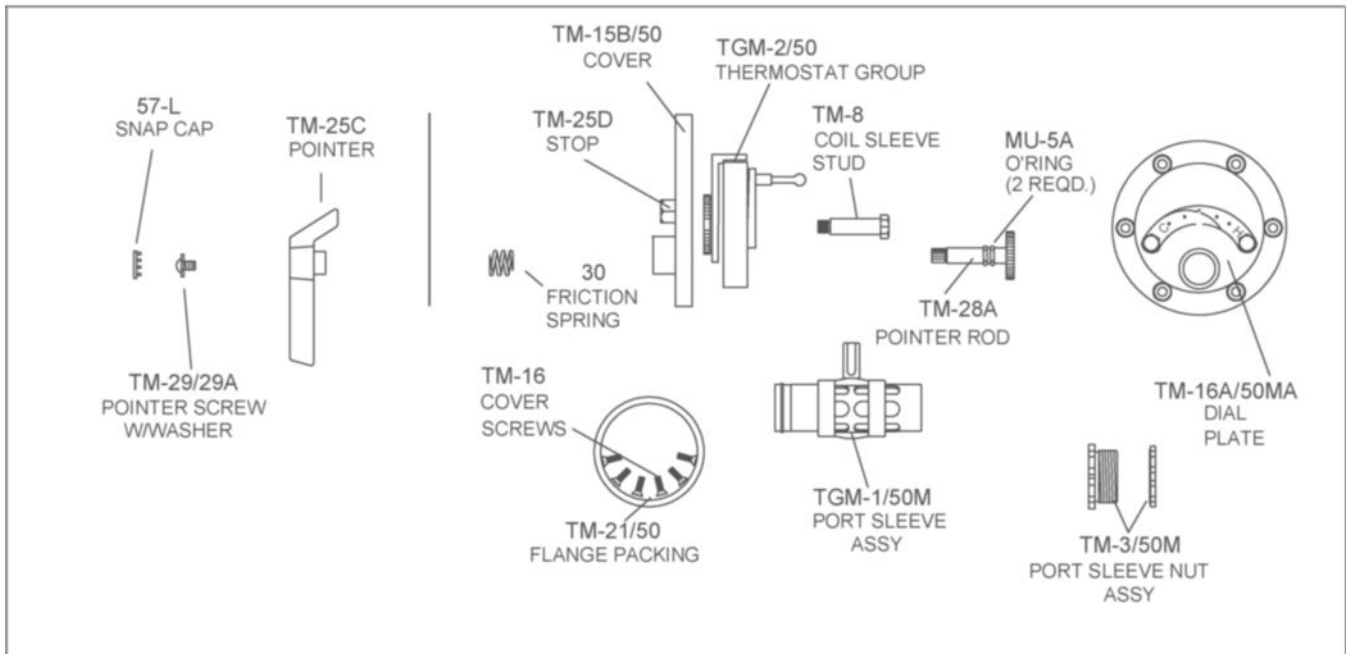

CHECKSTOP PARTS

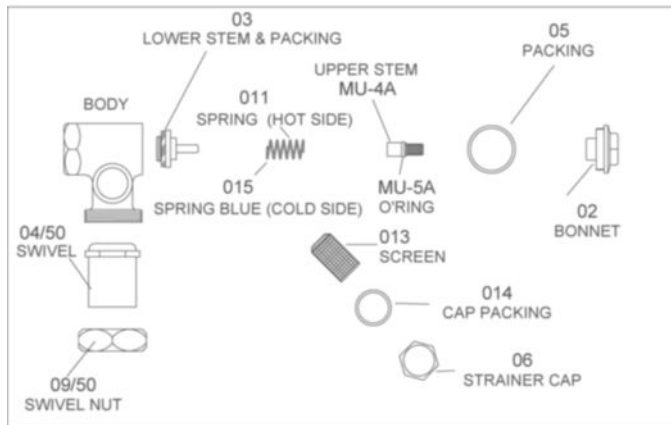

LOCK-TYPE POINTER (SUFFIX LTR)

Valves are furnished with lockable pointers. See part noted.



REMEMBER! THIS IS A CONTROL DEVICE WHICH MUST BE CLEANED AND MAINTAINED ON A REGULAR BASIS (SEE MAINTENANCE GUIDE AND RECORD, MGR-1000)

NOTE: AFTER INSTALLING NEW PARTS IT WILL BE NECESSARY TO RESET THE ADJUSTABLE HIGH TEMPERATURE LIMIT STOP (SEE PAGE 2).

REPAIR KITS

KIT 1/50M PACKINGS & GASKETS

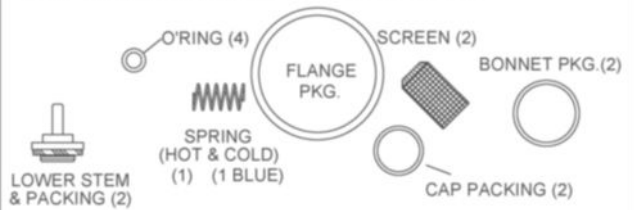

KIT R/50M REBUILDING KIT

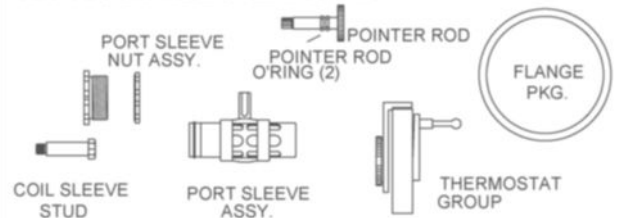

KIT 2/50M CHECKSTOP KIT

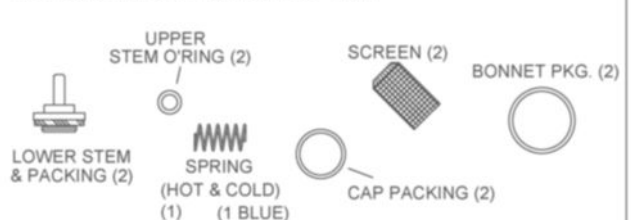

FLOW CAPACITIES

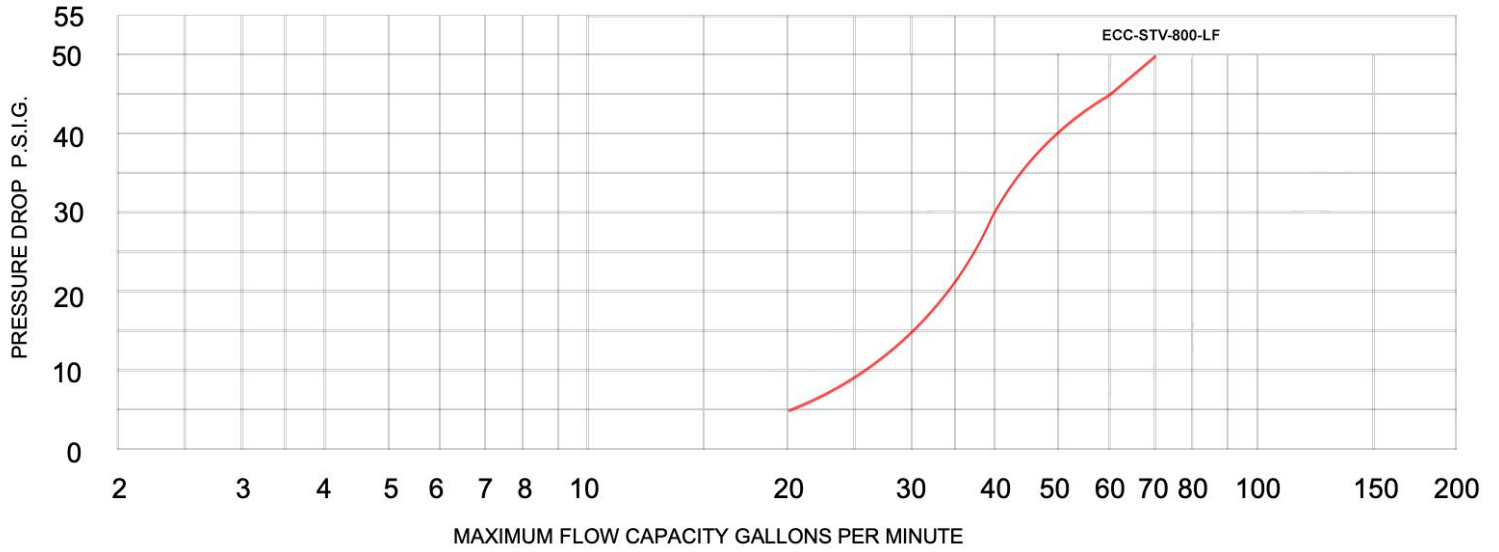

MODEL	IN	OUT	MINIMUM FLOW (GPM)	INTERNAL COLD WATER BY-PASS MINIMUM	PRESSURE DROP									PSI
					5	10	15	20	25	30	35	40	45	
			L\MIN		0.3	0.7	1.0	1.4	1.7	2.1	2.4	2.8	3.1	BAR
ECC-STV-800LF	1"	1 1/4"	3	20	20	25	30	33	35	38	43	50	56	GPM
			11	76	76	95	114	125	132	144	163	189	212	L\MIN
MAXIMUM FLOW CAPACITY														

WARRANTY STATEMENT

ENCON HEREBY DISCLAIMS ALL WARRANTIES EXPRESSED OR IMPLIED INCLUDING BUT NOT LIMITED TO WARRANTIES OF MERCHANTABILITY, FITNESS FOR A PARTICULAR PURPOSE, AND NON-INFRINGEMENT OF THIRD-PARTY RIGHTS, EXCEPT AS HEREINAFTER PROVIDED.

Encon Safety Products warrants that for one year from the date of purchase of any Encon products, the product will be free of defects in materials and workmanship if properly used and cared for or cleaned under normal conditions in accordance with Encon's use and care instructions and properly installed, if applicable, in accordance with Encon's installation instructions. With respect to the product, Encon's only obligation and purchaser's exclusive remedy under this warranty is to repair or replace such product; provided that:

1. Encon is notified of the defect within one year of shipment, and
2. the product is determined by Encon to be defective.

Encon requires proof of original ownership as proof of warranty coverage, and Encon must receive any claim under this Limited Warranty within one year of purchase of the product.

NOTWITHSTANDING ANYTHING TO THE CONTRARY CONTAINED HEREIN, ENCON SHALL NOT BE LIABLE FOR LOSS, DAMAGE, OR EXPENSE ARISING DIRECTLY OR INDIRECTLY AS A CONSEQUENCE OF USE OF THE EQUIPMENT WITH OTHER PRODUCTS OR FROM ANY OTHER CAUSE, INCLUDING ANY CONSEQUENTIAL, INCIDENTAL, SPECIAL OR EXEMPLARY DAMAGES, EXCEPT FOR ENCON'S OBLIGATION TO REPAIR OR REPLACE DEFECTIVE PRODUCTS AS EXPRESSLY PROVIDED IN THIS STATEMENT.

Replacement parts purchased from Encon are warranted for one year following the shipment of such replacement part, or until the expiration of the warranty period for the product, whichever is less. No warranty is given in connection with products that are altered without Encon's expressed written consent. The same warranty limitations and the obligations of Encon as set out herein above shall apply to replacement parts.

Encon's total liability arising out of this warranty (including, but not limited to, warranty claims) regardless of forum and regardless of whether such action or claim is based on tort, contract or otherwise will not exceed the total purchase price of the product.



6825 W. Sam Houston Pkwy. N
Houston, TX 77041
1-800-AT-ENCON / 1-800-283-6266
customerservice@enconsafety.com
<http://www.enconsafety.com>