

## PRODUCT DESCRIPTION

Stainless steel safety cabinet with modesty curtain installation instructions.

### Note:

1. Refer to assembly and installation detail drawings attached.
2. For best results, two persons are required to perform assembly of cabinet.
3. Install cage nuts where required prior to assembly.
4. Remove protective coating from all panels prior to assembly

### Caution:

1. To allow for proper alignment of panels, base of unit must be as level as possible.
2. Avoid completely tightening screws into nuts until all panels and top assembly are installed, unit is level, and the panels plum, fully tighten upon completion of assembly.
3. If using a power driven screwdriver, avoid marring stainless steel finish.

## PARTS LIST

### Stall Booth Containing:

- 1 – Base
- 1 – Top Assembly
- 1 – Top Plate
- 1 – Back Panel
- 1 – Interior Panel
- 2 – Side Panels (Right and Left)
- 1 – Drain Grate
- 30 – #10-32 Clinch Nut
- 30 – #10-32 X 5/16" SST Button HD. Sc.
- 80 – #10-32 SST Cage Nut
- 80 – #10-32 X 1/2" SST Button HD. Sc.
- 10 – #10-32 X 1" SST Button HD. Sc.
- 1 – #10-32 Allen Wrench Drill Bit

### Plumbing Kit Containing:

- 1 – Shower Head
- 1 – Shower Overhead Section
- 1 – Upper Vertical Section
- 1 – Fountain Section
- 1 – Pull Arm

### Hardware Package Containing

- 1 – 1" Pipe Clamp
- 2 – 1 1/4" Pipe Clamp
- 2 – Space Bar
- 6 – 1/4" – 20 X 7/8" Slotted Head Screw
- 6 – 1/4" – 20 Nut
- 1 – Flexible Rubber Boot
- 1 – Escutcheon Plate

### Curain Assembly Containing

- 1 – 1" Diameter Curtain Rod
- 2 – Shower Curtain

## ASSEMBLY

### Base Assembly

- 1) Stub-out drain 3" iron pipe standard (IPS) waste connection. Position base over waste pipe stubout with threshold facing front. Seal IPS to base by applying caulk to inside of drain connection. Install drain grate. See Figure 1.

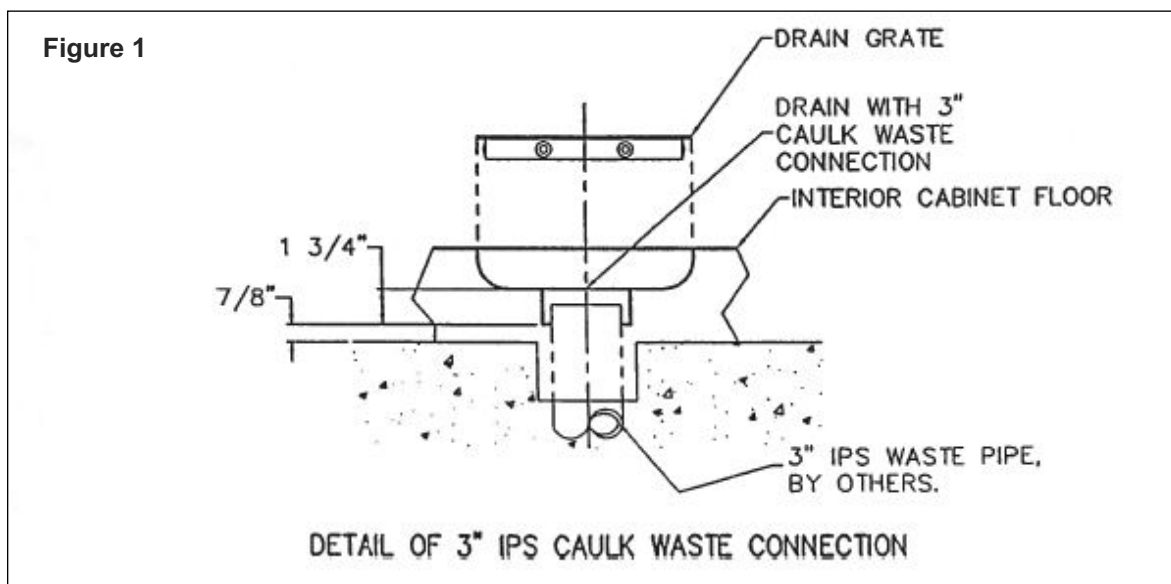

### **Right Panel Assembly**

- 1) Position right hand side panel onto base. Thread #10 x 5/16" long screws from inside of base into clinch nuts - located on outside of base.

**Note:** Position scored end of clinch nut toward screw. Clinch nut should recess onto opening along base bottom sides. Refer to Figure 2.

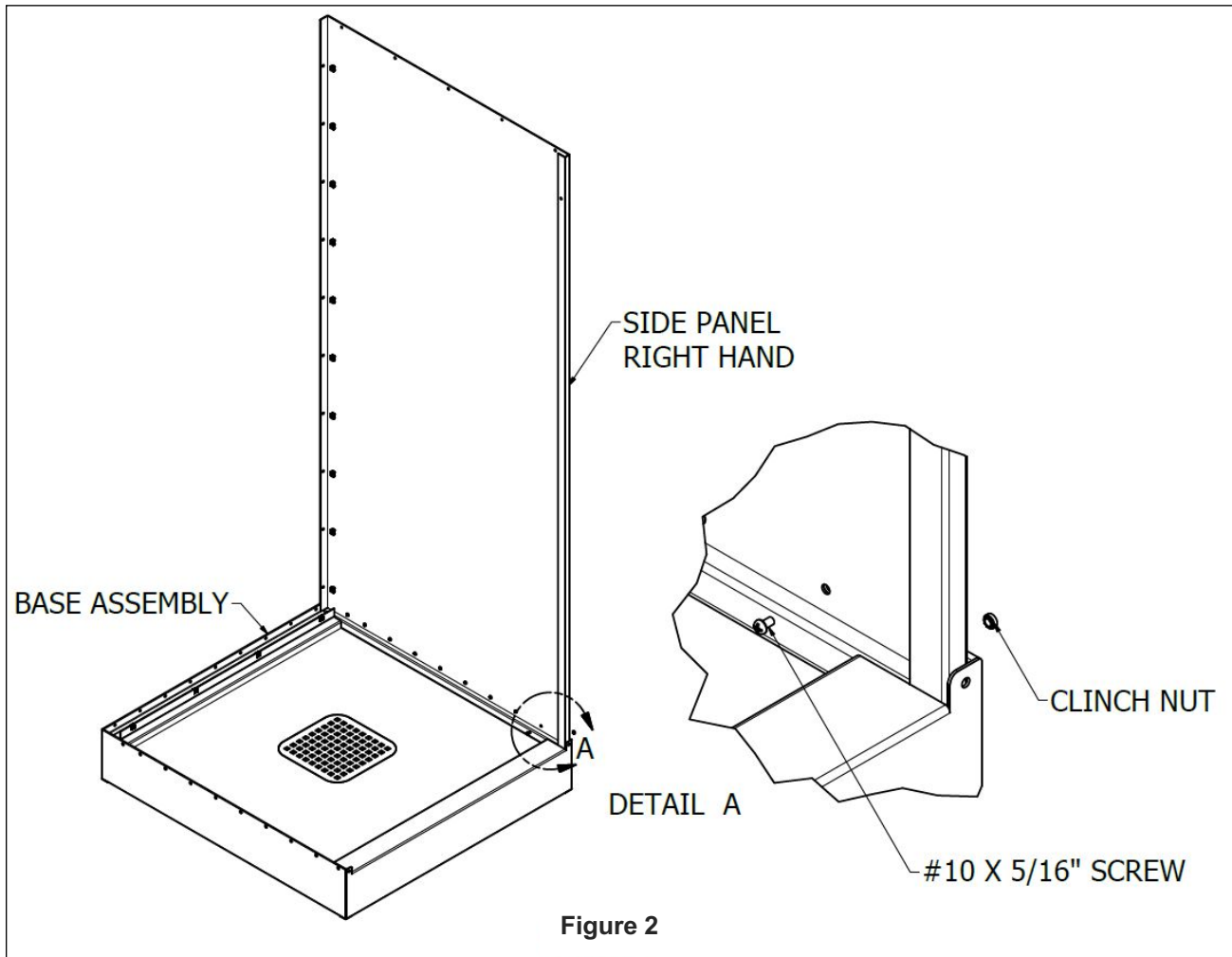

Figure 2

### Right Panel Assembly

- 1) Install cage nuts into punched holes in back panel. Refer to cage nut detail in appendix A. Position back panel within area at rear of base. Working from rear of cabinet, thread #10 x 1" long screws into cage nuts - located on back panel along bottom. Install #10 x 1/2" long screws vertically up installed right side panel. Refer to Figure 3.

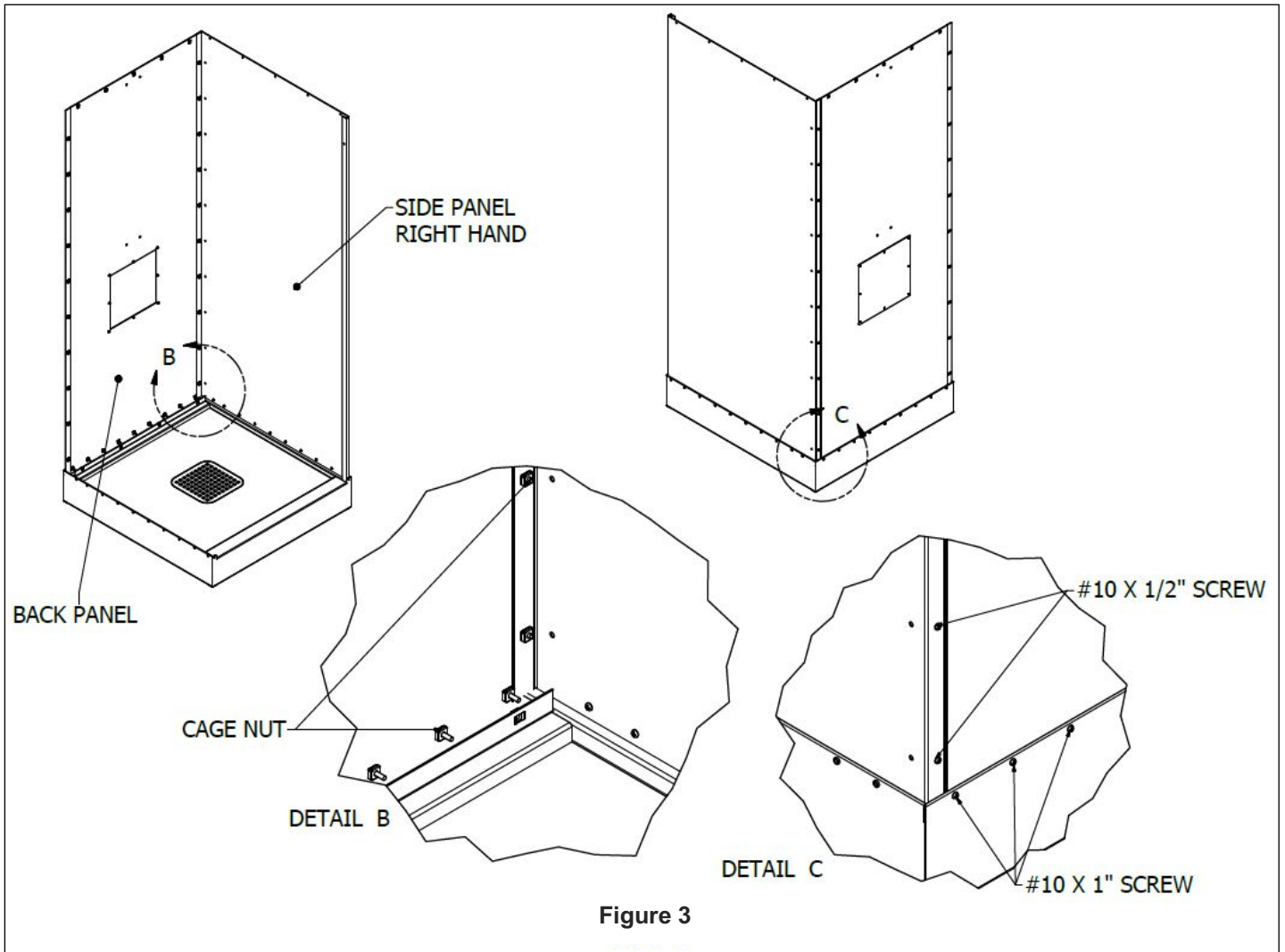
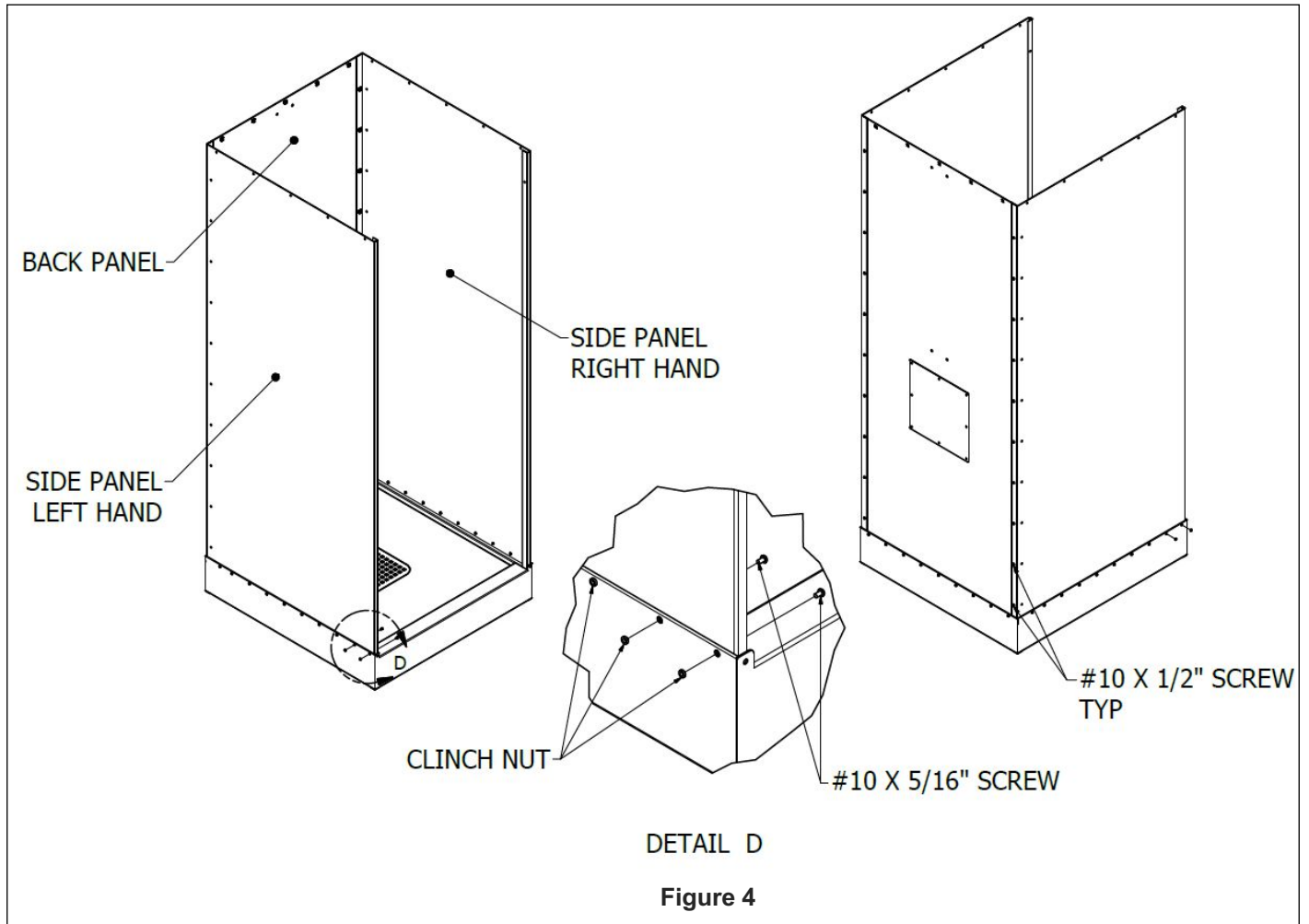

Figure 3

### Left Panel Assembly

- 1) Position left hand side panel onto base. Thread #10 x 5/16" long screws from inside of base into clinch nuts - located on outside of base. Refer to Figure 4.
- 2) Working from outside of side panel thread #10 x 1/2" long screws into cage nuts - vertically located on back panel. Refer to Figure 4.



### **Modesty Curtain Assembly**

- 1) Slide 1" diameter stainless steel tube through leather reinforced grommet holes in top of shower curtain. Ensure that the rod protrudes from each end of the curtain. Refer to Detail A.
- 2) Attach shower curtain and rod to the stall booth by positioning the rod over the bosses located in the upper right and left side of the cabinet. The bosses will insert into the rod and hold the assembly in place. Pressure on the side panels toward the center of the cabinet may be required to hold the curtain assembly in the correct position until the top assembly is installed.

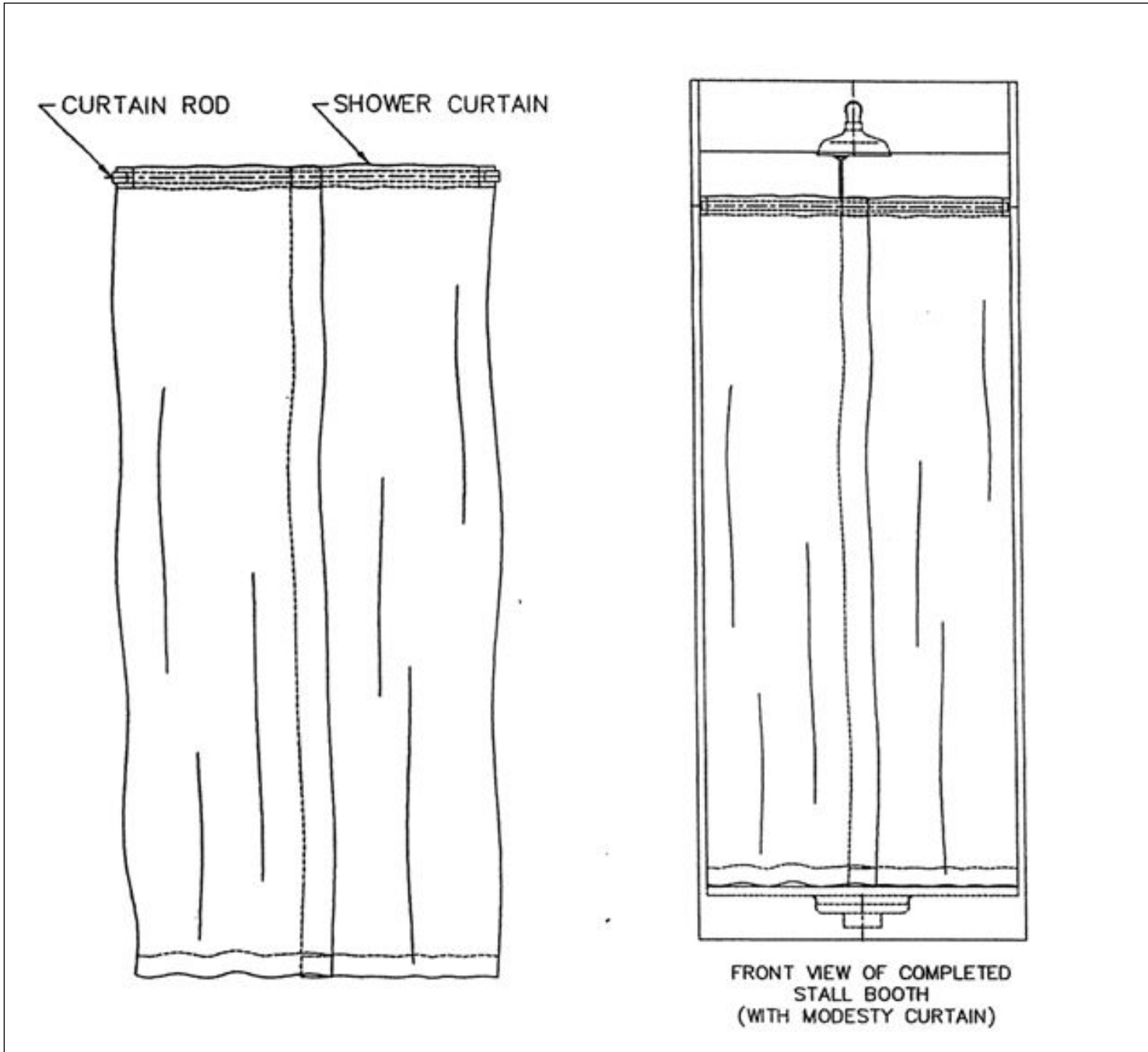

### Top Assembly

- 1) Position top assembly (without Top Plate) above cabinet assembly. Position top assembly with ceiling opening facing the rear of cabinet. Slide top assembly over outside of cabinet.
- 2) Thread #10 x 5/16" long screws from outside of cabinet into clinch nuts - located on inside of cabinet along top of left and right hand panels. Refer to Figure 5.
- 3) Thread #10 x 5/16" long screws from outside of cabinets into cage nuts- located along top of back panel. Refer to Figure 5.

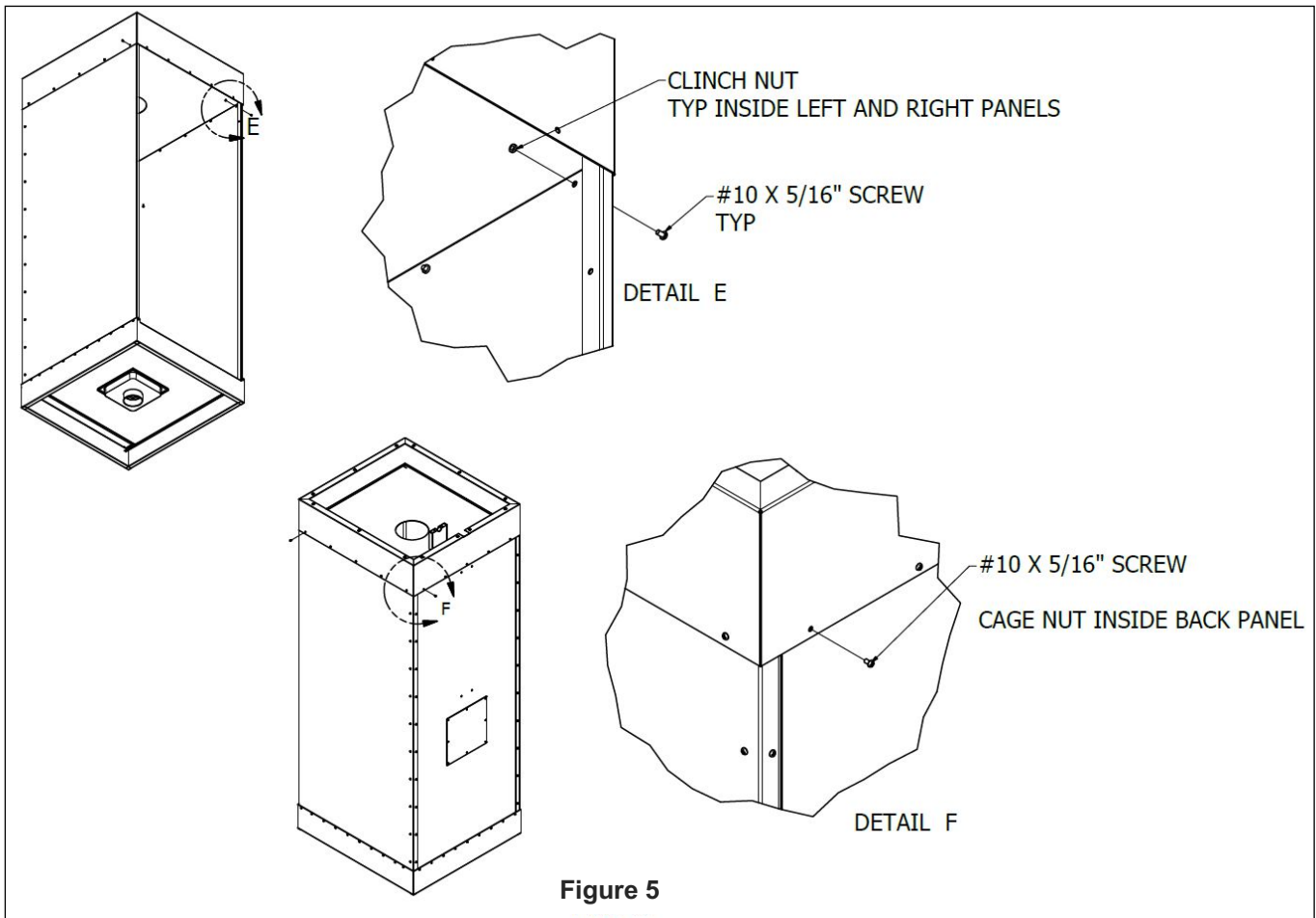

## Shower Pipe Assembly

- 1) Attach shower overhead section to upper vertical section. Care must be taken to properly align the overhead section and the elbow/bushing on the upper vertical. The two must be aligned to ensure proper installation. See Figure 6.
- 2) Install overhead section/upper vertical in stall unit by placing piping assembly flat against interior back wall. Raise piping assembly until overhead section is through opening in top assembly. Rotate piping assembly until overhead section rests in the pipe saddle in the top assembly.
- 3) Secure piping assembly to stall booth back panel with 1 1/4" pipe clamps and spacers provided. Insert 1/4"-20 x 7/8" long screw from back of back panel. The spacers install between back panel and upper vertical section. Secure clamps with 1/4"-20 lock nuts. Do not fully tighten nuts at this time. See Figure 6.
- 4) Install 1" pipe clamp in top assembly pipe saddle using remaining 1/4"-20 screws and lock nuts.
- 5) Attach showerhead to piping overhead section. From inside stall booth, pass showerhead through opening in the ceiling of the top assembly. Start threads and tighten by hand to secure the showerhead in position. From the top of the stall booth, tighten showerhead to proper thread engagement. The showerhead must be level with the shower floor. If necessary, adjust the piping assembly to level showerhead.
- 6) Secure piping assembly to stall booth by completely tightening screws and lock nuts.

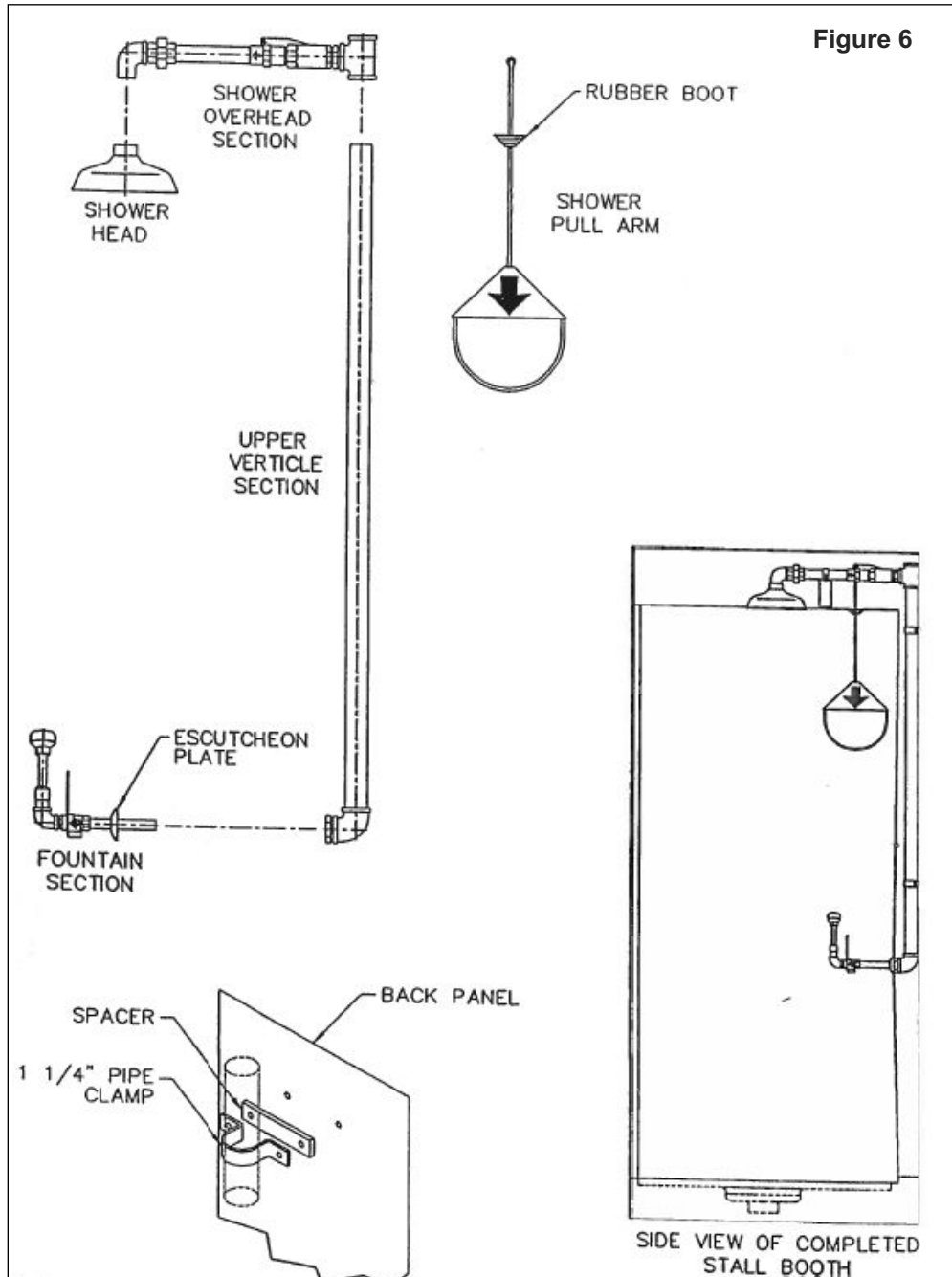

### Interior Panel Assembly

- 1) Inside stall, insert cage nuts in lower backing angle, located on backside of base. See Figure 7.
- 2) Insert cage nuts into right and left side of interior panel.
- 3) Position interior panel against right side panel. Working from outside of right side panel thread #10 x 1/2" long screws into cage nuts - vertically located on interior panel. Refer to Figure 7.
- 4) Use same procedure to secure left side of interior panel.
- 5) Attach interior panel to lower backing angle by threading #10 x 1/2" long screws from entry side into lower backing angle cage nuts. Refer to Figure 7.
- 6) From within cabinet attach top assembly to interior wall by threading #10 x 1/2" long screws from entry side into upper backing angle cage nuts. Refer to Figure 7.

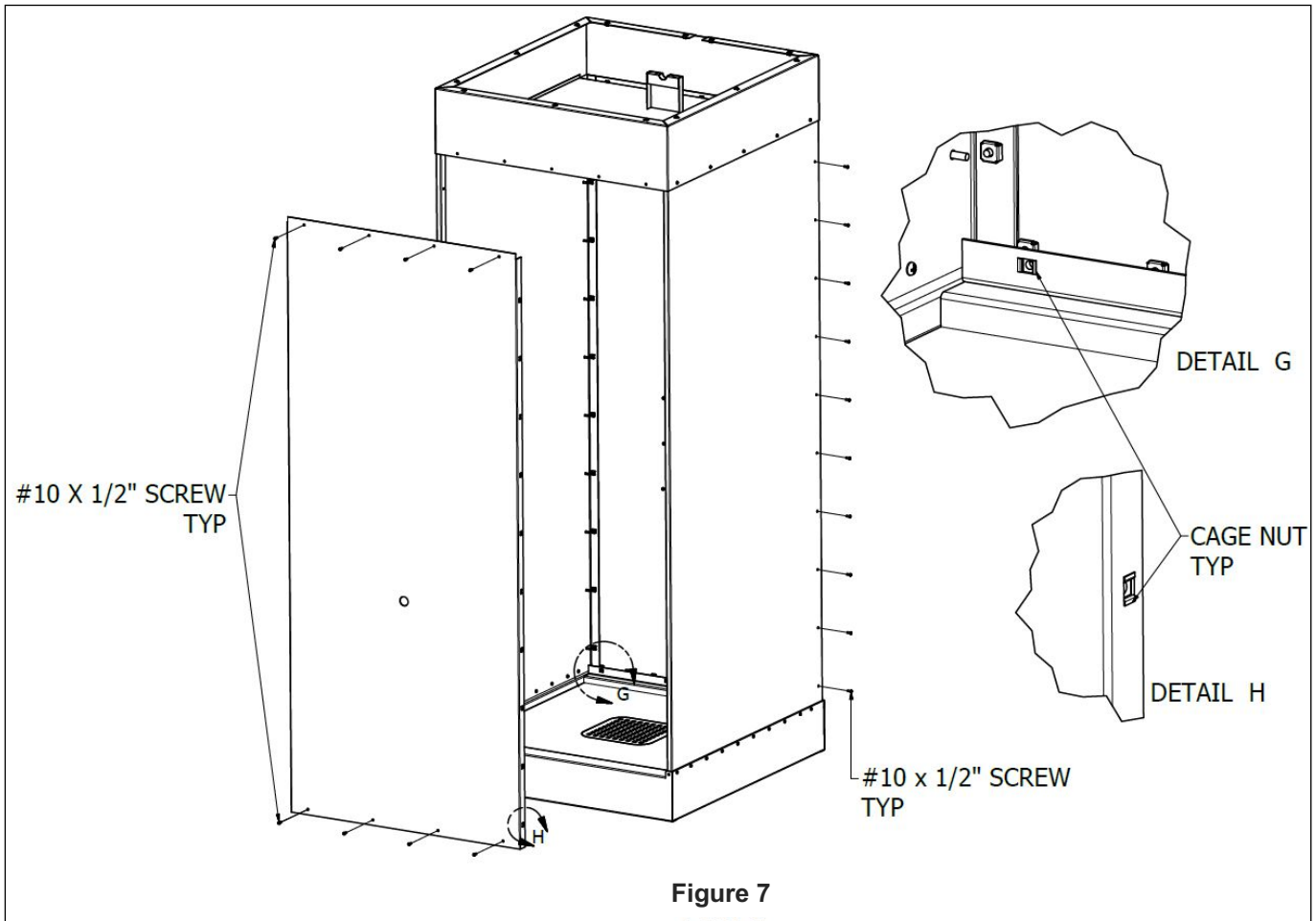
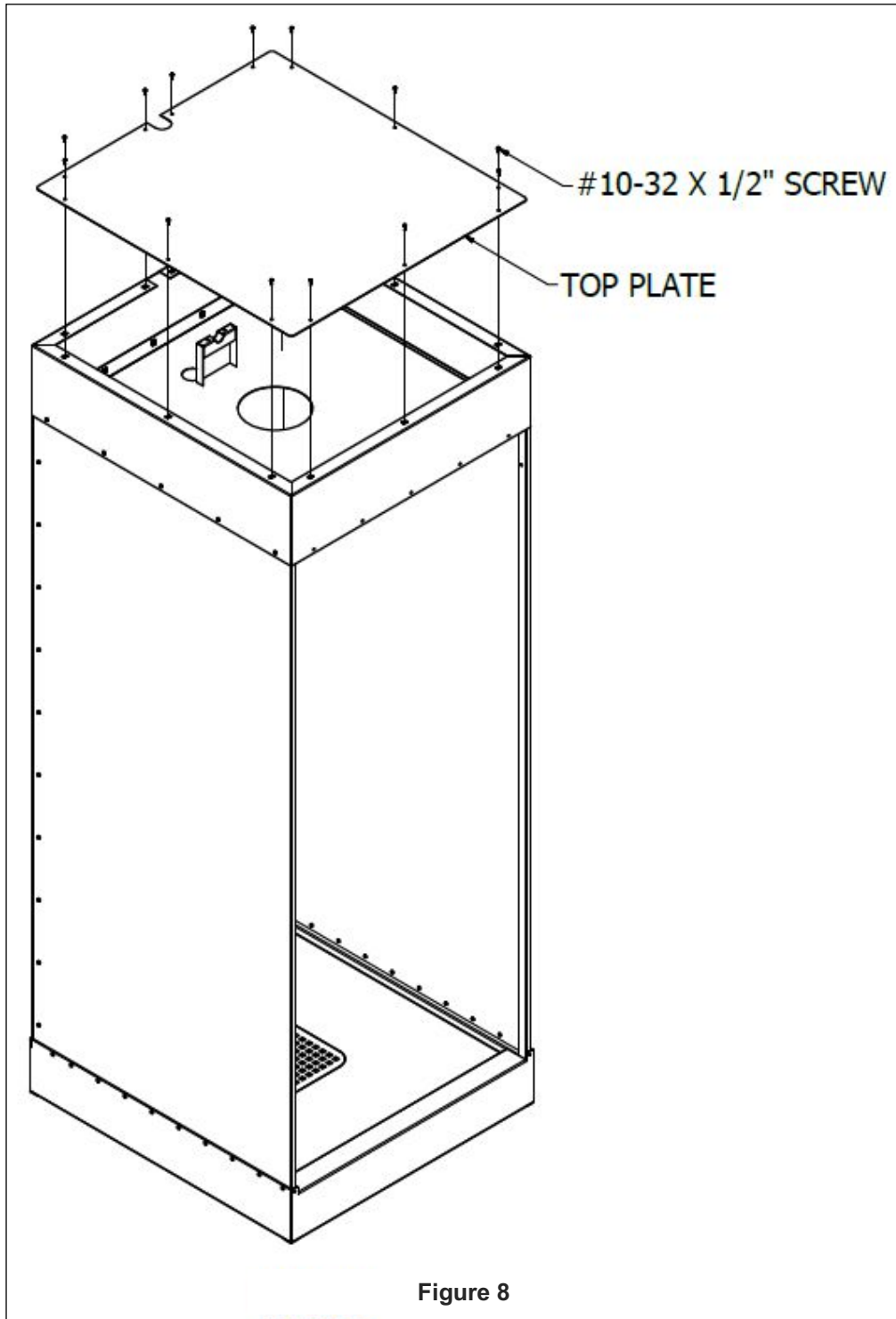

Figure 7



### **Final Assembly**

- 1) Slide escutcheon plate on 1/2" pipe nipple on fountain section. Install fountain section through access hole in interior panel and into upper vertical section. Ensure that the fountain section is level to floor. Slide escutcheon against interior panel. See Figure 6.
- 2) Slide rubber boot over shower pull arm. From interior of stall booth, pass shower pull arm through access hole in ceiling of top assembly and attach to overhead section actuator arm. Secure to actuator arm with washer and cotter pin. Slide boot into hole in ceiling.
- 3) Install top plate. Fully tighten all hardware. Refer to Figure 8.



**HARDWARE INSTALLATION DETAIL**

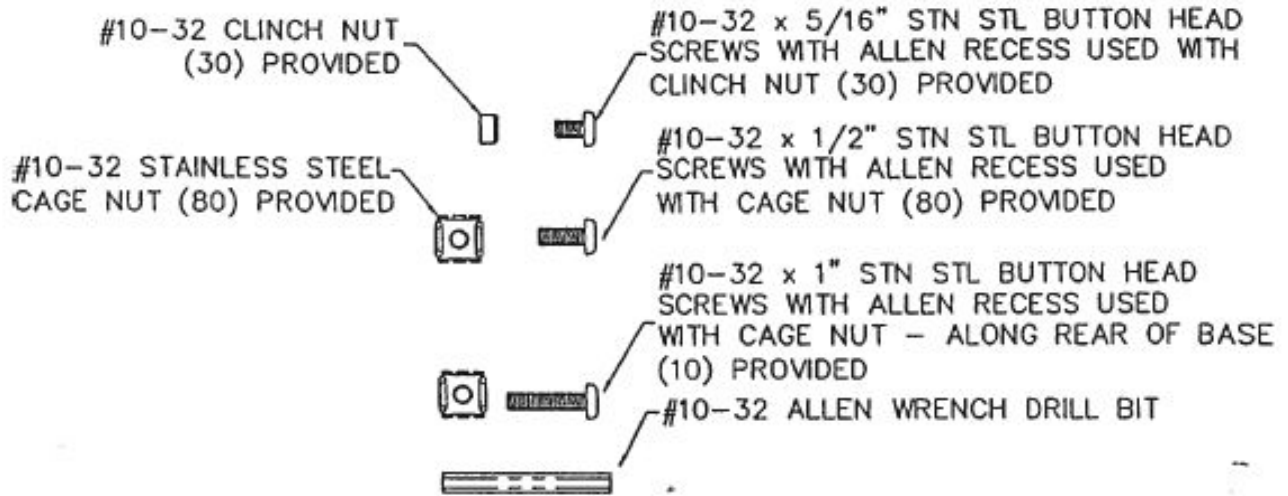

**DETAIL OF FACTORY PROVIDED FASTENERS**

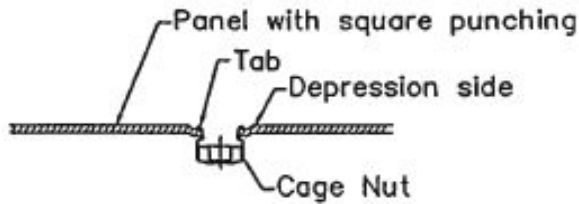

Use flathead screwdriver to push cage nut tab inward toward center of nut. This will allow tabs to fit through punching. Insert cage nut with tabs located on depression side. Release Tab.

**CAGE NUT INSTALLATION DETAIL**

## OPERATION & MAINTENANCE

1. Plumbed units shall be activated weekly to flush lines and verify proper flow pattern and volume.
2. Test records should be maintained verifying compliance with testing procedures.
3. Some chemical vapors or liquids may damage or soften plastic materials. Precaution should be taken to determine compatibility prior to installation.

## TRAINING

All employees who might be exposed to hazardous material shall be instructed in the location and proper use of emergency shower and eye/facewash units. Experiences have shown that initial first-aid treatment for irritates should be to wash the eyes and face for 15 minutes prior to medical treatment. It is important to hold the eyelids open and roll the eyes so water will flow on all surfaces and in the folds surrounding the eyes.

## PROPOSITION 65

WARNING: This product can expose you to BPA, which is known to the State of California to cause birth defects or other reproductive harm. For more information go to [www.P65Warnings.ca.gov](http://www.P65Warnings.ca.gov).

## WARRANTY STATEMENT

ENCON HEREBY DISCLAIMS ALL WARRANTIES EXPRESSED OR IMPLIED INCLUDING BUT NOT LIMITED TO WARRANTIES OF MERCHANTABILITY, FITNESS FOR A PARTICULAR PURPOSE, AND NON-INFRINGEMENT OF THIRD-PARTY RIGHTS, EXCEPT AS HEREINAFTER PROVIDED.

Encon Safety Products warrants that for one year from the date of purchase of any Encon products, the product will be free of defects in materials and workmanship if properly used and cared for or cleaned under normal conditions in accordance with Encon's use and care instructions and properly installed, if applicable, in accordance with Encon's installation instructions. With respect to the product, Encon's only obligation and purchaser's exclusive remedy under this warranty is to repair or replace such product; provided that:

1. Encon is notified of the defect within one year of shipment, and
2. the product is determined by Encon to be defective.

Encon requires proof of original ownership as proof of warranty coverage, and Encon must receive any claim under this Limited Warranty within one year of purchase of the product.

NOTWITHSTANDING ANYTHING TO THE CONTRARY CONTAINED HEREIN, ENCON SHALL NOT BE LIABLE FOR LOSS, DAMAGE, OR EXPENSE ARISING DIRECTLY OR INDIRECTLY AS A CONSEQUENCE OF USE OF THE EQUIPMENT WITH OTHER PRODUCTS OR FROM ANY OTHER CAUSE, INCLUDING ANY CONSEQUENTIAL, INCIDENTAL, SPECIAL OR EXEMPLARY DAMAGES, EXCEPT FOR ENCON'S OBLIGATION TO REPAIR OR REPLACE DEFECTIVE PRODUCTS AS EXPRESSLY PROVIDED IN THIS STATEMENT.

Replacement parts purchased from Encon are warranted for one year following the shipment of such replacement part, or until the expiration of the warranty period for the product, whichever is less. No warranty is given in connection with products that are altered without Encon's expressed written consent. The same warranty limitations and the obligations of Encon as set out herein above shall apply to replacement parts.

Encon's total liability arising out of this warranty (including, but not limited to, warranty claims) regardless of forum and regardless of whether such action or claim is based on tort, contract or otherwise will not exceed the total purchase price of the product.



6825 W. Sam Houston Pkwy. N  
Houston, TX 77041  
1-800-AT-ENCON / 1-800-283-6266  
[customerservice@enconsafety.com](mailto:customerservice@enconsafety.com)  
<http://www.enconsafety.com>